

1 2 3 4 5 6



A A

B B

C C

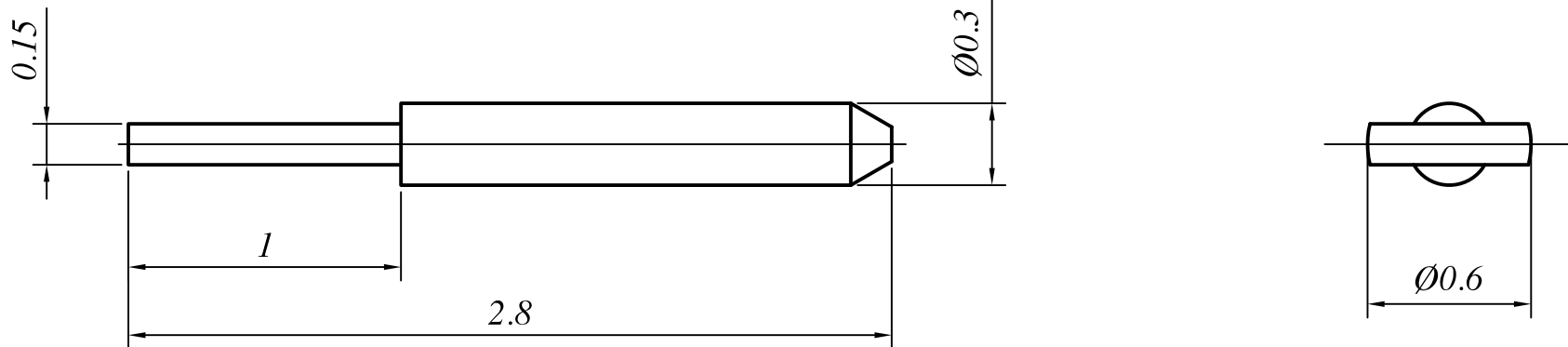
D D



		4th Floor, West Unit, Incubation Building 1 Guanghua Lu, Nanjing TEL: 025-84304950 FAX: 025-84304959 WWW.ALLWINTEK.COM		DIRECTION OF VIEW 		UNIT mm		TITLE PIN			
PROPRIETARY INFORMATION: THE INFORMATION WHEN THIS DRAWING IS PROPRIETARY AND SHALL NOT BE USED OR DISCLOSED WITHOUT PRIOR WRITTEN PERMISSION FROM ALLWIN TECHNOLOGY.				DRAWN Weihao Pan CHECKED Shaoqing Du APPR. Dong Wu		DWG NO. L10S12-03		OUTLINE DRAWING			
UNLESS OTHERWISE SPECIFIED: 1. REMOVE ALL BURRS, BREAK ALL CORNERS, SHARP EDGES 0.05 R MAX 2. LINEARITY TOLERANCES ± 0.2 , ANGLE TOLERANCES $\pm 1^\circ$ 3. DIAMETERS ON COMMON CENTERS TO BE CONCENTRIC WITHIN 0.1 4. ALL DIMENSIONS ARE AFTER PLATING, SURFACE FINISHED ✓				DO NOT SCALE DRAWING		SIZE A4 h		SCALE 40:1		REV. V2.0 SHEET 1/1	
LTR	DESCRIPTION	DATE	APPR.								

1 2 3 4 5 6